

3D MASTER

DRIVE ACCURACY INTO YOUR BUSINESS

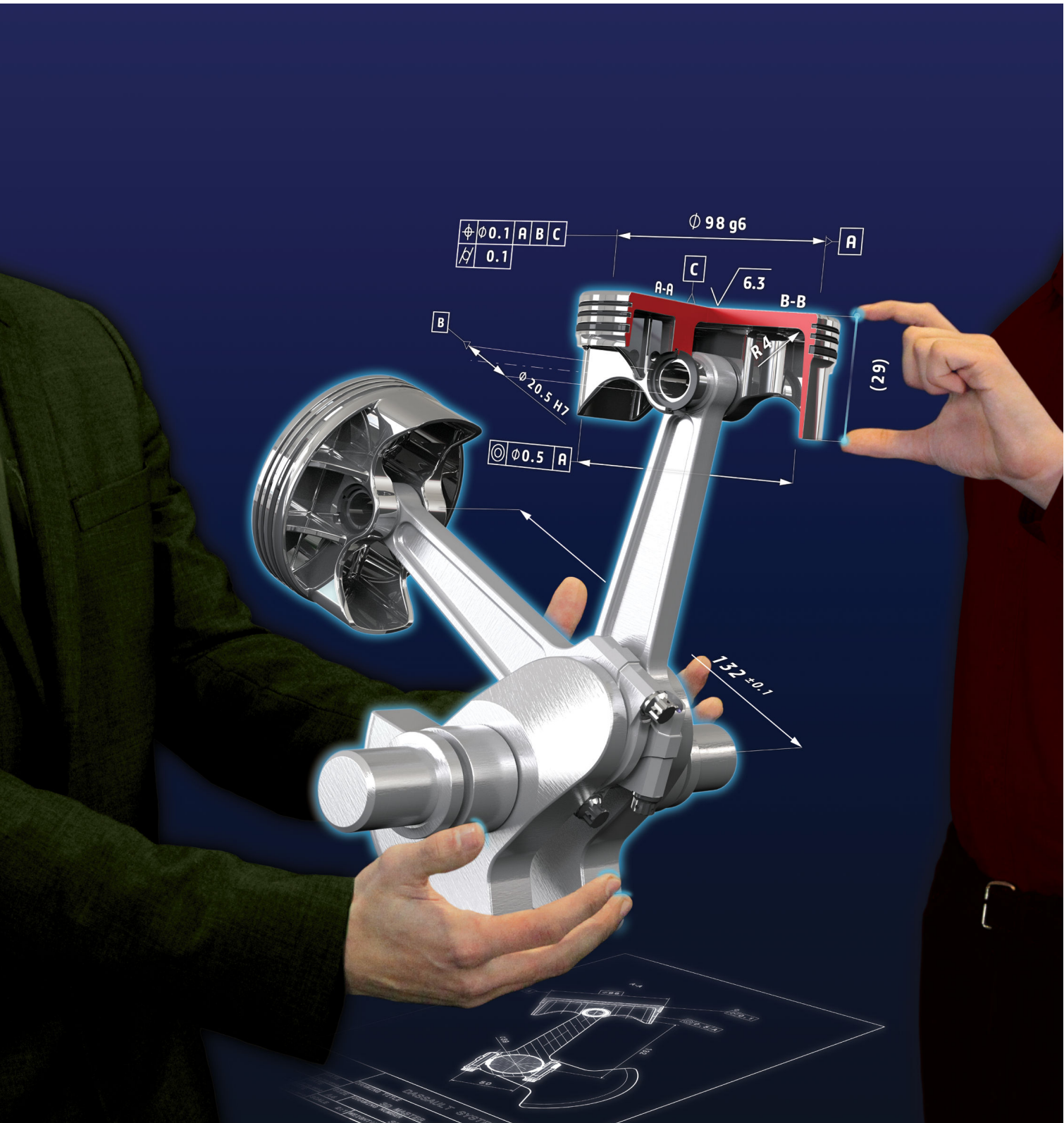

Contents

- 3 Introduction
- 4 Challenges with a 2D alone design environment
- 6 Key values of the 3D Master concept
- 8 Gain significant ROI and improve product quality by embracing this end-to-end concept
- 9 Achieving significant benefits with 3D Master
- 10 Frequently asked questions about the 3D Master approach
- 11 Conclusion

Introduction

With today's ongoing global pressures, organizations need to drive innovation and be first to market with new products, ensuring the highest quality at the lowest cost.

Traditional design methods using 2D drawings are central to the product development process and historically have served as the reference for product definition. Many companies are increasingly realizing that 2D drawings alone are insufficient and often lead to design errors and higher manufacturing costs. As a result, a new trend called 3D Master is on the rise. 3D Master empowers all functions within a company to find, share, annotate and improve products using the richest format of information - 3D. This approach provides a number of important benefits, such as the ability to replicate and reuse the product definition for variants, lower cost and improve quality of the product design and development process and eliminate errors. Many companies have moved away from 2D drawings to the 3D Master model in order to achieve these benefits. However, many other companies will continue to use 2D drawings while leveraging 3D models as the master and they too are seeing similar benefits.

This whitepaper will examine the 3D Master approach, its associated benefits and real world successes achieved by adopting this strategic direction.

Evolution of the design process



Historical evolution of the 3D Master concept

Challenges with a 2D alone design environment

For centuries the dimensioned 2D drawing played the central role in the process of designing and building products of all types. Drawings typically provide an understanding of how the product will function and will be manufactured as well as the dimensions and tolerances needed to ensure fit and functionality. Drawing standards such as ANSI/ASME, ISO and JIS standardized the meaning and the appearance of drawings which increased their value by making them easier to understand across the organization and up and down the supply chain.

But there have always been challenges involved in trying to describe a 3D world in a 2D drawing. It is very difficult to unambiguously describe a complex 3D part in a series of 2D drawings. Misunderstandings were common and these often resulted in costly delays and sometimes in the construction of bad parts. Many 2D drawings were often required to describe a single 3D part or assembly. When design changes were made, a difficult and error-prone process was required which often involved correcting many drawings.

The advent first of 3D computer aided design (CAD) and later of solid modeling provided a major advance. Solid modeling provides the ability to unambiguously define 3D geometries in a single geometrical file. Furthermore, the solid model provides the ability to verify the form, fit and functionality of the product prior to construction of prototypes. The ability to evaluate more designs in less time has led to improvements in product performance and reductions in late stage design changes.

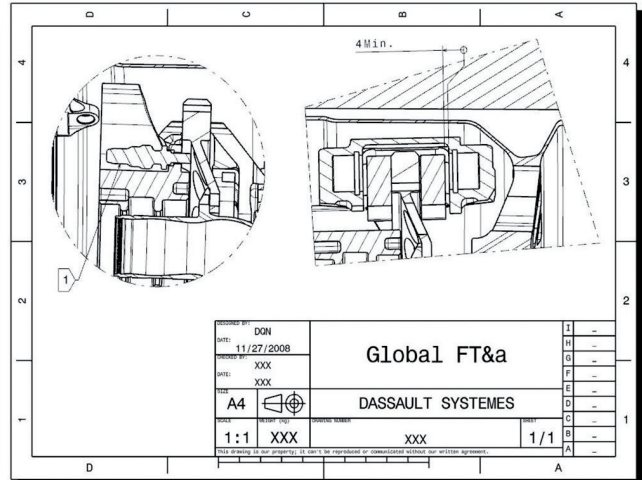

Despite 3D modeling's large adoption, 2D still remains "the reference" for product definition

But 2D drawings have continued to play an important role in the design process by providing tolerancing, annotations, parts lists and other information that is critical to downstream processes, such as manufacturing, quality control and the supply chain. Without the third dimension, all of the planes and features in any view are all on top of each other even if they are at the ends of the part. So it is extremely difficult to create 2D sections that accurately and completely show the key features and surfaces that tolerances and annotations are applied to. This often leads to errors because downstream users cannot identify exact part features when looking at a 2D drawing of a complex part.

The difficulty in understanding 2D drawings is increased by the fact that 2D design standards are not common around the world. In particular, the use of third angle projection in Europe is the equivalent of a foreign language and can be extremely confusing.

One more concern is that when inevitable design changes occur, three different datasets - the solid model, 2D drawings and parts lists - usually need to be updated. It is possible for any of these datasets to get out of sync with the others, requiring additional time to maintain them. This often results in delays for design changes or making the incorrect parts.

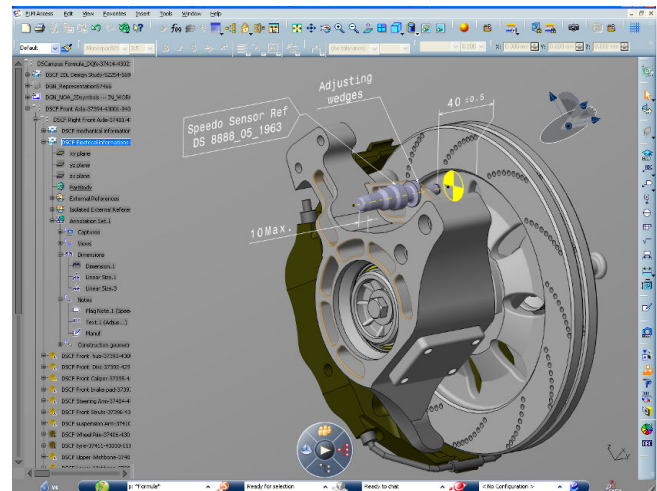

3D functional tolerancing & annotations to assist the designer during product definition

Key values of the 3D Master concept

The latest generation of solid modeling systems makes it possible to insert the dimensions, geometry design and tolerancing, annotations and parts lists directly into the solid model, eliminating the need for drawings. Any number of views of the 3D model can be composed, detailed and annotated for specific downstream groups such as manufacturing planning, product services, procurement and marketing /sales. For example, a live 3D model with a prescribed series of annotated and dimensioned views can be provided to a contract manufacturer.

The latest generation of solid modeling software allows easy creation of associative 3D tolerance specifications and annotations. A full set of GD&Ts (geometric dimensioning & tolerancing) are provided including datum elements and datum targets and text and flag-note annotations to complete the 3D definition. A tolerancing advisor guides the user through the process of putting geometrical tolerances on the part while preventing the creation of an invalid tolerance. For example, when creating a flatness tolerance for the top face of a part, the advisor filters out options that are not valid for a single surface. The tolerancing meaning is captured in the dataset to be directly reused by downstream applications such as tolerance analysis, manufacturing or inspection and to check the dimensioning and tolerancing validity throughout the design stage. In this scenario, a parallelism tolerance will be turned to invalid and highlighted to the designer if the features are no longer parallel after a geometry change.

2D layout for 3D design capabilities enables users to work in a 3D environment with advanced 2D drafting capabilities during the conceptual phase of a project. 2D geometry can be exported as profiles and planes for fast and easy 3D geometry creation. Dimensioning and tolerancing annotation data can be added during the preliminary phase, eliminating the need for it to be recreated in a downstream process.

The 3D Master can be shared with people across the value chain by providing free or inexpensive lightweight viewing applications. Virtual teams and communities can meet in a real-time environment to search, navigate, chat and collaborate on any aspect of a product related program. The environment improves decision-making by providing early and direct insight into dimensioning and tolerancing annotations, geometrical elements and features, and the relationships between elements.

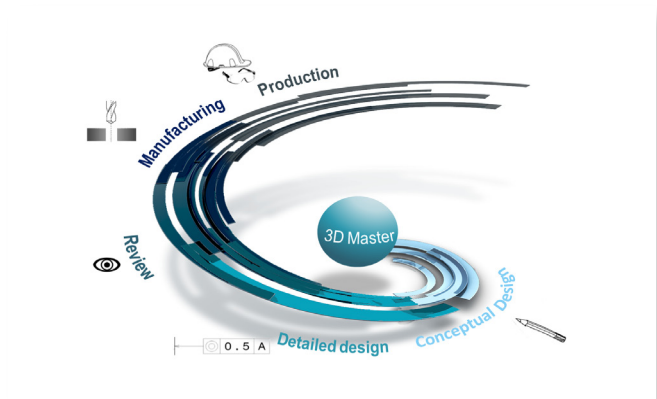

3D Master is the unique reference for product description across all phases of the development cycle.

Gain significant ROI and improve product quality by embracing this end-to-end concept

Consolidating the solid model of the part geometry, tolerance and annotations and parts list into a single dataset offers major advantages. Working with a 3D model, the engineer can be absolutely certain that he or she is applying the tolerance to the desired feature and anyone using this information can be sure they are producing or measuring the correct feature. Confusion over different 2D drawing standards is eliminated because 3D is universal and looks the same to everyone everywhere.

The 3D Master approach also provides considerable savings in re-use of product definition information in product families or future versions of the product. Product Lifecycle Management (PLM) systems greatly enhance the ability to re-use geometric information. The 3D Master approach makes it just as easy to re-use the complete product definition, including tolerance and annotations and parts lists. Advanced users can create templates containing tolerancing and annotations and parts lists that make it possible to automate new areas of the product development process.

Another advantage of incorporating tolerancing into the solid model is that it opens the door to reducing manufacturing costs by opening up unnecessarily tight tolerances. Incorporating the tolerances in a 3D Master model makes it much easier to use tolerance analysis tools that predict the assembly variations based on the tolerancing specified for individual parts while taking both deformation and the assembly

process into account. Simulating the build variation determines if the product and process, as designed, meets the dimensional product requirements and determines the impact of individual tolerances on the assembly variation. This type of simulation often makes it possible to loosen tolerances, resulting in manufacturing cost reductions of up to 90%.

Finally, the possibility of the geometry, tolerancing and annotations and parts list getting out of sync is nearly eliminated. This greatly reduces the potential for errors which in turn reduces time-to-market and product development costs. The time and money required to maintain, distribute and search for product definition information is also substantially reduced by putting everything in a single container.

Achieving significant benefits with 3D Master

A company that produces helicopters for commercial and military applications provides an example of how the 3D Master approach can improve data quality. In the past, the company faced challenges with data quality, shop floor errors, supply chain data inefficiencies and the need to improve time to market and time to volume. Dassault Systèmes worked with the company to implement the 3D Master approach and transfer best practices and methodologies. It took about six months to implement the most representative and complex domain which involved about 100 designers. The new approach provides 100% reliable and accurate 3D definition to manufacturing which helps prevent errors. Providing one data reference also eliminates the cost of managing multiple drawings. The 3D definition is now re-used for the inspection plan and first assembly inspection review, providing further improvements in accuracy and a reduction in data management costs.

A major aerospace and defense supplier deployed the 3D Master approach for the tooling design process in its aerostructures department. A 3D Master center of excellence trained tooling suppliers to understand 3D Master prior to quoting and during early use to minimize impacts. Internal users were trained in the use of 3D Master data and the center of excellence served as a focal point for questions. Cultural change was expedited by making the 3D Master approach mandatory. The company achieved a 20% to 30% reduction in tooling costs by preventing errors due to inconsistent and incorrect product definitions without passing costs onto tooling suppliers.

One of the world's leading automobile manufacturers has implemented a drawing-free, end-to-end full 3D Master approach for their body-in-white in production for the past five years. On a floor panel, which served as a reference part, up to 100 pieces of information are added to the 3D model. The 3D Master has been rolled out to 600 internal users and 200 suppliers. The use of the 3D Master approach for the vehicle powertrain is now in pilot. The reference part is a cylinder head which requires 800 separate annotations and tolerances. This application involves a potential user base of 350 internal users and 350 suppliers. The ability to copy functional tolerancing and annotations from an existing part to a new variant means that 70% of the production definition can be created with virtually no effort. Automatic tolerancing makes it possible to define a catalog of tolerances and have them applied without any effort. 2D blueprints are automatically generated for suppliers that are unable to work with a 3D model. Manufacturing costs have been reduced by encouraging designers to loosen up tolerances without affecting product quality.

A leading producer of trucks and mass transit vehicles ensures data consistency by automatically generating 2D data based on the 3D Master model. This approach provides as early as possible a complete 3D product definition that delivers rich content for downstream processes such as technical publications, assembly line work instructions, the supply chain, etc. A light 3D viewer is provided to suppliers, quality control and the shop floor. Young designers are also motivated by the opportunity to work with a complete 3D product definition.

The company has 800 users in production. The time required to create the product definition has been substantially reduced.

A manufacturer of business jets has produced the first 3D Master model that has been approved by the Federal Aviation Administration. The initial 3D Master implementation was for interior outfitting and the company's latest jet was defined entirely using the 3D Master concept. The company achieved a 40% increase in productivity and nearly doubled the delivery rate without increasing costs. Most importantly, the plane was delivered on time.

Frequently asked questions about the 3D Master approach

What kind of ROI can I expect with 3D Master deployment? You can expect major improvements in global design, manufacturing process definition, data exchanges with suppliers and partners due to the reduction of drawings and the elimination of redundant data and effort. One major manufacturer achieved a 20% to 30% time savings in its global design and manufacturing process. Another invested \$20 million and saved \$500 million in five years by introducing 3D Master.

Is it possible to implement 3D Master without eliminating drawings? Drawings are one way to present the 3D Master definition so you can convert to the 3D Master approach and still use drawings wherever you wish.

I don't think my engineers will be able to learn how to work in 3D efficiently from the user's standpoint, 3D Master is very similar to creating 2D drawings. If you already know how to make a drawing, you will only need one and a half days training to learn FT&A. Engineers working for companies that have implemented 3D Master are nearly unanimous in saying they don't want to go back to drawings.

My certification organization doesn't accept 3D Master. You can produce presentation drawings from the 3D Master product definition and use them for certification. But most certification organizations, such as the FAA, are now accepting 3D certifications.

The solid model contains intellectual property that I do not want to share a product data filtering tool is available that will extract only the information that you want to provide to a partner.

What is the best way to work with a small partner that cannot invest in a 3D CAD solution? Lightweight viewing solutions are available at no cost.

How can 3D Master provide an improvement in productivity at the design stage if you are basically doing the same job in 3D as you did in 2D drawings before? One of our customers stated that at the design stage, 50% of the engineers' time is spent in creating or updating 2D drawings. They told us that they can have up to 5 different drawings for different purposes for the same part. You can imagine the benefits of having a single 3D source containing all product definition that can be reused to serve various purposes.

Conclusion

Despite the broad adoption of 3D modeling, the 2D drawing remains the primary reference for dimensions, tolerances and annotations for 90% of manufacturing companies. The central concept of the 3D Master approach is that the 3D product model is the most appropriate vehicle for delivering the detailed product information needed by downstream processes. By converting to the 3D Master method, companies can:

- Define 100% of the product definition using a single 3D dataset.
- Reduce the cost and improve the quality of the product development process.
- Substantially increase the amount of design information that can be re-used in future variants.
- Reduce manufacturing costs by optimizing manufacturing tolerances.



Delivering Best-in-Class Products



Virtual Product Design



Model and Simulate our Planet



3D for Professionals



Information Intelligence



Realistic Simulation



Dashboard Intelligence



Virtual Production



Social Innovation



Global Collaborative Lifecycle Management



Online 3D Lifelike Experiences

Dassault Systèmes, the **3DEXPERIENCE** Company, provides business and people with virtual universes to imagine sustainable innovations. Its world-leading solutions transform the way products are designed, produced, and supported. Dassault Systèmes' collaborative solutions foster social innovation, expanding possibilities for the virtual world to improve the real world. The group brings value to over 150,000 customers of all sizes in all industries in more than 80 countries. For more information, visit 3DS.COM.

CATIA, SOLIDWORKS, SIMULIA, DELMIA, ENOVIA, GEOVIA, EXALEAD, NETVIBES, 3DSW4M, 3DVIA are registered trademarks of Dassault Systèmes or its subsidiaries in the US and/or other countries.

Europe/Middle East/Africa
Dassault Systèmes
10, rue Marcel Dassault
CS 40501
78946 Vélizy-Villacoublay Cedex
France

Asia-Pacific
Dassault Systèmes
Pier City Shibaura Bldg 10F
3-18-1 Kaigan, Minato-Ku
Tokyo 108-002
Japan

Americas
Dassault Systèmes
175 Wyman Street
Waltham, Massachusetts
02451-1223
USA

Visit us at
3DS.COM/3DMASTER
